

Vorkheftrucks met verbrandingsmotor 3.5 - 8.0 t

TONERO



Vorkheftrucks met verbrandingsmotor 3.5 - 4.0 t

Specificaties					40-8FD35N	8FG35N	40-8FD40N	8FG40N
Kenmerken	1.1	Fabrikant			TOYOTA	TOYOTA	TOYOTA	TOYOTA
	1.2	Type			40-8FD35N	8FG35N	40-8FD40N	8FG40N
	1.3	Aandrijving			Diesel	LPG	Diesel	LPG
	1.4	Besturing			Zittend	Zittend	Zittend	Zittend
	1.5	Hefvermogen	Q	kg	4000 (3500)	4000 (3500)	4500 (4000)	4500 (4000)
	1.6	Bij lastzwaartepunt	c	mm	500 (600)	500 (600)	500 (600)	500 (600)
	1.8	Lastafstand	x	mm	505	505	505	505
	1.9	Wielbasis	y	mm	1900	1900	1900	1900
	Gewicht	2.1	Eigen gewicht		kg	5780	5700	6150
2.2		Asbelasting met last voor/achter		kg	8110/1170	8090/1110	8830/1320	8810/1260
2.3		Asbelasting zonder last voor/achter		kg	2570/3210	2550/3150	2500/3650	2480/3590
Wielen en banden	3.1	Banden - Lucht (P), Volrubber (SE), Cushion (R)			P	P	P	P
	3.2	Bandenmaat voor			250-15-16PR	250-15-16PR	250-15-16PR	250-15-16PR
	3.3	Bandenmaat achter			7.00-12-12PR	7.00-12-12PR	7.00-12-12PR	7.00-12-12PR
	3.5	Wielen, aantal voor/achter (x = aangedreven)			2/2	2/2	2/2	2/2
	3.6	Spoorbreedte voor	b ₁₀	mm	1115	1115	1115	1115
	3.7	Spoorbreedte achter	b ₁₁	mm	1100	1100	1100	1100
	Afmetingen	4.1	Neiging mast/voorover/achterover	α/β	deg	6/12	6/12	6/12
4.2		Bouwhoogte, mast ingeschoven	h ₁	mm	2110	2110	2110	2110
4.3		Vrije heffing	h ₂	mm	110	110	110	110
4.4		Hefbeweging	h ₃	mm	2950	2950	2950	2950
		Hefhoogte	h ₂₃	mm	3000	3000	3000	3000
4.5		Hoogte, mast in hoogste stand	h ₄	mm	4270	4270	4270	4270
4.7		Hoogte beschermdak (cabine)	h ₆	mm	2285	2285	2285	2285
4.8		Zithoogte	h ₇	mm	1128	1128	1128	1128
4.12		Hoogte trekpen	h ₁₀	mm	420	420	420	420
4.19		Totale lengte	l ₁	mm	3925	3925	3980	3980
4.20		Lengte incl. vorkrug	l ₂	mm	2925	2925	2980	2980
4.21		Totale breedte	b ₁	mm	1350	1350	1350	1350
4.22		Vorkafmetingen	s/e/l	mm	50/150/1000	50/150/1000	50/150/1000	50/150/1000
4.23		Vorkenbord DIN 15173, klasse/type A, B			IIIA	IIIA	IIIA	IIIA
4.24		Breedte vorkenbord	b ₃	mm	1170	1170	1170	1170
4.31		Bodemvrijheid belast, onderkant mast	m ₁	mm	120	120	120	120
4.32		Bodemvrijheid midden wielbasis	m ₂	mm	200	200	200	200
4.33		Gangpadbreedte bij pallets 1000 x 1200 dwars	A _{st}	mm	4315	4315	4365	4365
4.34	Gangpadbreedte bij pallets 800 x 1200 langs	A _{st}	Mm	4515	4515	4565	4565	
4.35	Draaistraal	W _a	mm	2610	2610	2660	2660	
4.36	Binnenstraal	b ₁₃	mm	940	940	990	990	
Prestaties	5.1	Rijsnelheid met/zonder last		km/h	23/24	23/24	23/24	23/24
	5.2	Hefsnelheid met/zonder last		m/s	0,56/0,57	0,56/0,57	0,56/0,57	0,56/0,57
	5.3	Daalsnelheid met/zonder last		m/s	0,53/0,48	0,53/0,48	0,53/0,48	0,53/0,48
	5.6	Maximale trekkracht met/zonder last		N	37400/13500	37000/13400	37000/13000	36000/13000
	5.7	Klimvermogen met/zonder last		%	35	34	30	32
	5.8	Maximaal klimvermogen met/zonder last		%	45/24	43/24	40/21	42/21
5.10	Bedrijfsrem			Hydraulisch	Hydraulisch	Hydraulisch	Hydraulisch	
Motor	7.1	Fabrikant motor / type			TOYOTA 1KD	TOYOTA 1FS	TOYOTA 1KD	TOYOTA 1FS
	7.2	Motorvermogen volgens 1585		kW	55	63	55	63
	7.3	Bij toerental		1/min	2200	2350	2200	2350
	7.4	Aantal cilindres / cilinderinhoud		cm ³	4/2982	4/3685	4/2982	4/3685
	7.5a	Brandstofverbruik volgens VDI-cyclus 60		l/h	4,3	—	4,6	—
	7.5b	Brandstofverbruik volgens VDI-cyclus 60		kg/h	—	4,2	—	4,5
Andere	8.2	Werkdruk voor aanbouwapparatuur		bar	185	185	185	185
	8.3	Olie voor aanbouwapparatuur		l/min	128	128	128	128
	8.4	Geluidsniveau op oorhoogte chauffeur, soort EN 12 053		dB(A)	77	80	77	80

De prestaties en afmetingen van de truck zijn gebaseerd op nominale waarden. Hierop zijn enige afwijkingen mogelijk. De producten van Toyota en de technische gegevens van de producten kunnen zonder voorafgaand bericht worden gewijzigd.

Mastspecificaties and restcapaciteit

Model		V						FV					FSV							
8FG/D35,40N	Hefhoogte	h_{23}	3000	3300	3700	4000	4500	5000	3000	3300	3500	3700	4000	4000	4300	4500	4700	5000	5500	6000
	Hefbeweging	h_3	2950	3250	3650	3950	4450	4950	2950	3250	3450	3650	3950	3950	4250	4450	4650	4950	5450	5950
	Masthoogte, mast ingeschoven	h_1	2110	2290	2490	2740	2990	3240	2110	2290	2390	2490	2740	2110	2160	2225	2290	2390	2540	2740
	Masthoogte, mast in hoogste stand ¹⁾	h_4	3850	4150	4550	4850	5350	5850	3880	4180	4380	4580	4880	4880	5180	5380	5580	5880	6380	6880
	Masthoogte, mast in hoogste stand ²⁾	h_4	4270	4570	4970	5270	5770	6270	4270	4570	4770	4970	5270	5270	5570	5770	5970	6270	6770	7270
	Vrije heffing, zonder lastrek	h_2	110	110	110	110	110	110	1280	1460	1560	1660	1910	1280	1330	1395	1460	1560	1710	1910
	Vrije heffing, met lastrek	h_2	110	110	110	110	110	110	890	1070	1170	1270	1520	890	940	1005	1070	1170	1320	1520

1) Zonder lastrek.

2) Met lastrek; Hoogte standaard lastrek is 1220 mm.

Enkele Wielen			V						FV					FSV						
8FG/D35N	Neighoek, voorw.	deg	6	6	6	6	6	6	6	6	6	6	6	6	6	6	6	6	6	6
	Neighoek, achterw.	deg	12	12	12	12	12	6	12	12	12	12	12	6	6	6	6	6	6	6
	Hefvermogen op 500 mm LC	kg	4000	4000	4000	4000	4000	3800	4000	4000	4000	4000	4000	4000	3800	3700	3700	3600	3000	2200
	Hefvermogen op 600 mm LC	kg	3500	3500	3500	3500	3500	3500	3500	3500	3500	3500	3500	3500	3500	3500	3500	3400 (3450)	2800 (2850)	2100 (2150)
8FG/D40N	Neighoek, voorw.	deg	6	6	6	6	6	6	6	6	6	6	6	6	6	6	6	6	6	6
	Neighoek, achterw.	deg	12	12	12	12	6	6	12	12	12	12	12	6	6	6	6	6	6	6
	Hefvermogen op 500 mm LC	kg	4500	4500	4500	4500	4500	4200	4500	4500	4500	4500	4500	4500	4500	4500	4500	4400	3500	2700
	Hefvermogen op 600 mm LC	kg	4000	4000	4000	4000	4000	4000	4000	4000	4000	4000	4000	4000	4000	4000	4000	4000	3500 (3550)	2700 (2750)

Dubbele Wielen			V						FV					FSV						
8FG/D35N	Neighoek, voorw.	deg	6	6	6	6	6	6	6	6	6	6	6	6	6	6	6	6	6	6
	Neighoek, achterw.	deg	12	12	12	12	12	12	12	12	12	12	12	6	6	6	6	6	6	6
	Hefvermogen op 500 mm LC	kg	4000	4000	4000	4000	4000	3800	4000	4000	4000	4000	4000	4000	3800	3700	3700	3600	3500	3400
	Hefvermogen op 600 mm LC	kg	3500	3500	3500	3500	3500	3500	3500	3500	3500	3500	3500	3500	3500	3500	3500	3400	3300	3200
8FG/D40N	Neighoek, voorw.	deg	6	6	6	6	6	6	6	6	6	6	6	6	6	6	6	6	6	6
	Neighoek, achterw.	deg	12	12	12	12	12	12	12	12	12	12	12	6	6	6	6	6	6	6
	Hefvermogen op 500 mm LC	kg	4500	4500	4500	4500	4500	4400	4500	4500	4500	4500	4500	4500	4500	4500	4500	4400	4200	3300
	Hefvermogen op 600 mm LC	kg	4000	4000	4000	4000	4000	4000	4000	4000	4000	4000	4000	4000	4000	4000	4000	4000	4000	3300

() = Hefvermogen met PSC wielen.

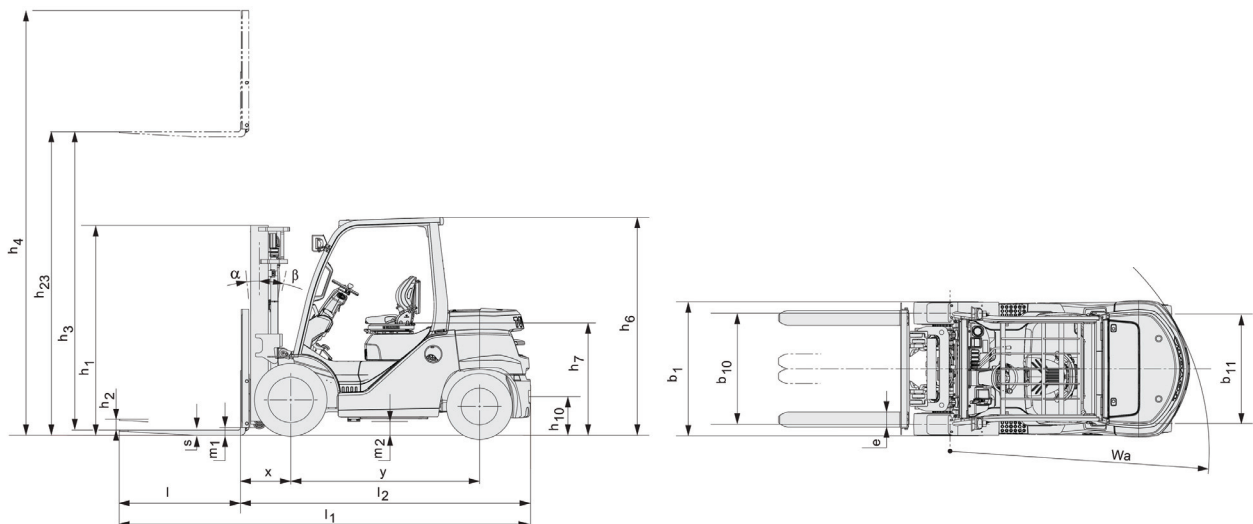

Vorkheftrucks met verbrandingsmotor 4.5 - 5.0 t

Specificaties					40-8FD45N	8FG45N	40-8FD50N	8FG50N
Kenmerken	1.1	Fabrikant			TOYOTA	TOYOTA	TOYOTA	TOYOTA
	1.2	Type			40-8FD45N	8FG45N	40-8FD50N	8FG50N
	1.3	Aandrijving			Diesel	LPG	Diesel	LPG
	1.4	Besturing			Zittend	Zittend	Zittend	Zittend
	1.5	Hefvermogen	Q	kg	4990 (4500)	4990 (4500)	5000	5000
	1.6	Bij lastzwaartepunt	c	mm	500 (600)	500 (600)	600	600
	1.8	Lastafstand	x	mm	545	545	555	555
	1.9	Wielbasis	y	mm	2000	2000	2000	2000
	Gewicht	2.1	Eigen gewicht		kg	6690	6610	7220
2.2		Asbelasting met last voor/achter		kg	9920/1270	9900/1210	10910/1310	10880/1260
2.3		Asbelasting zonder last voor/achter		kg	2850/3840	2830/3780	3030/4190	3000/4140
Wielen en banden	3.1	Banden - Lucht (P), Volrubber (SE), Cushion (R)			P	P	P	P
	3.2	Bandenmaat voor			300-15-18-PR	300-15-18-PR	300-15-18PR	300-15-18PR
	3.3	Bandenmaat achter			7.00-12-12PR	7.00-12-12PR	7.00-12-14-PR	7.00-12-14-PR
	3.5	Wielen, aantal voor/achter (x = aangedreven)			2/2	2/2	2/2	2/2
	3.6	Spoorbreedte voor	b ₁₀	mm	1115	1115	1115	1115
	3.7	Spoorbreedte achter	b ₁₁	mm	1100	1100	1100	1100
	Afmetingen	4.1	Neiging mast/voorover/achterover	α/β	deg	6/12	6/12	6/12
4.2		Bouwhoogte, mast ingeschoven	h ₁	mm	2200	2200	2450	2450
4.3		Vrije heffing	h ₂	mm	110	110	120	120
4.4		Hefbeweging	h ₃	mm	2950	2950	2950	2940
		Hefhoogte	h ₂₃	mm	3000	3000	3000	3000
4.5		Hoogte, mast in hoogste stand	h ₄	mm	4270	4270	4435	4435
4.7		Hoogte beschermdak (cabine)	h ₆	mm	2375	2375	2375	2375
4.8		Zithoogte	h ₇	mm	1223	1223	1223	1223
4.12		Hoogte trekpen	h ₁₀	mm	420	420	420	420
4.19		Totale lengte	l ₁	mm	4110	4110	4170	4370
4.20		Lengte incl. vorkrug	l ₂	mm	3110	3110	3170	3170
4.21		Totale breedte	b ₁	mm	1450	1450	1450	1450
4.22		Vorkafmetingen	s/e/l	mm	50/150/1000	50/150/1000	60/150/1200	60/150/1200
4.23		Vorkenbord DIN 15173, klasse/type A, B			IIIA	IIIA	IVA	IVA
4.24		Breedte vorkenbord	b ₃	mm	1170	1170	1170	1170
4.31		Bodemvrijheid belast, onderkant mast	m ₁	mm	120	120	120	120
4.32		Bodemvrijheid midden wielbasis	m ₂	mm	230	230	230	230
4.33	Gangpadbreedte bij pallets 1000 x 1200 dwars	A _{st}	mm	4495	4495	4565	4565	
4.34	Gangpadbreedte bij pallets 800 x 1200 langs	A _{st}	mm	4695	4695	4765	4765	
4.35	Draaistraal	W _a	mm	2750	2750	2810	2810	
4.36	Binnenstraal	b ₁₃	mm	1045	1045	1030	1030	
Prestaties	5.1	Rijsnelheid met/zonder last		km/h	23,5/24	23,5/24	23,5/24	23,5/24
	5.2	Hefsnelheid met/zonder last		m/s	0,48/0,50	0,48/0,50	0,48/0,50	0,48/0,50
	5.3	Daalsnelheid met/zonder last		m/s	0,54/0,49	0,54/0,49	0,54/0,49	0,54/0,49
	5.6	Maximale trekkracht met/zonder last		N	37000/15000	36000/15000	37000/16000	36000/16000
	5.7	Klimvermogen met/zonder last		%	28	30	25	23
	5.8	Maximaal klimvermogen met/zonder last		%	36/22	38/22	32/22	31/22
	5.10	Bedrijfsrem			Hydraulisch	Hydraulisch	Hydraulisch	Hydraulisch
Motor	7.1	Fabrikant motor / type			TOYOTA 1KD	TOYOTA 1FS	TOYOTA 1KD	TOYOTA 1FS
	7.2	Motorvermogen volgens 1585		kW	55	63	55	63
	7.3	Bij toerental		1/min	2200	2350	2200	2350
	7.4	Aantal cilindres / cilinderinhoud		cm ³	4/2982	4/3685	4/2982	4/3685
	7.5a	Brandstofverbruik volgens VDI-cyclus 60		l/h	5,0	—	5,3	—
	7.5b	Brandstofverbruik volgens VDI-cyclus 60		kg/h	—	4,9	—	5,2
Andere	8.2	Werkdruk voor aanbouwapparatuur		bar	185	185	185	185
	8.3	Olie voor aanbouwapparatuur		l/min	128	128	128	128
	8.4	Geluidsniveau op oorhoogte chauffeur, soort EN 12 053		dB(A)	77	80	77	80

De prestaties en afmetingen van de truck zijn gebaseerd op nominale waarden. Hierop zijn enige afwijkingen mogelijk. De producten van Toyota en de technische gegevens van de producten kunnen zonder voorafgaand bericht worden gewijzigd.

Mastspecificaties and restcapaciteit

Model			V						FV					FSV							
8FG/D45N	Hefhoogte	h_{23}	3000	3300	3700	4000	4500	5000	3000	3300	3500	3700	4000	—	4000	4300	4500	4700	5000	5500	6000
	Hefbeweging	h_3	2950	3250	3650	3950	4450	4950	2950	3250	3450	3650	3950	—	3950	4250	4450	4650	4950	5450	5950
	Masthoogte, mast ingeschoven	h_1	2200	2350	2600	2800	3050	3300	2200	2350	2450	2600	2800	—	2120	2200	2270	2350	2450	2600	2800
	Masthoogte, mast in hoogste stand ¹⁾	h_4	3690	3990	4420	4770	5270	5770	3740	4040	4240	4440	4740	—	4740	5045	5240	5440	5740	6240	6740
	Masthoogte, mast in hoogste stand ²⁾	h_4	4270	4570	4970	5270	5770	6270	4270	4570	4910	4970	5270	—	5270	5570	5770	5970	6270	6770	7270
	Vrije heffing, zonder lastrek	h_2	110	110	110	110	110	110	1510	1660	1760	1910	2110	—	1430	1510	1580	1660	1760	1910	2110
	Vrije heffing, met lastrek	h_2	110	110	110	110	110	110	980	1130	1230	1380	1580	—	900	980	1030	1130	1230	1380	1580

1) Zonder lastrek.

2) Met lastrek; Hoogte standaard lastrek is 1220 mm.

Model			V						FV					FSV							
8FG/D50N	Hefhoogte	h_{23}	3000	3300	3700	4000	4500	5000	—	—	—	—	—	3700	4000	4300	—	4700	5000	5500	6000
	Hefbeweging	h_3	2940	3240	3640	3940	4440	4940	—	—	—	—	—	3640	3940	4240	—	4640	4940	5440	5940
	Masthoogte, mast ingeschoven	h_1	2450	2600	2800	3050	3300	3550	—	—	—	—	—	2200	2270	2350	—	2450	2600	2800	3050
	Masthoogte, mast in hoogste stand ¹⁾	h_4	3905	4205	4605	4905	5405	5905	—	—	—	—	—	4635	4935	5235	—	5635	5935	6435	6935
	Masthoogte, mast in hoogste stand ²⁾	h_4	4435	4735	5135	5435	5935	6435	—	—	—	—	—	5135	5435	5735	—	6135	6435	6935	7435
	Vrije heffing, zonder lastrek	h_2	125	125	125	125	125	125	—	—	—	—	—	1330	1400	1480	—	1580	1730	1930	2180
	Vrije heffing, met lastrek	h_2	125	125	125	125	125	125	—	—	—	—	—	830	900	980	—	1080	1230	1430	1680

1) Zonder lastrek.

2) Met lastrek; Hoogte standaard lastrek is 1370 mm.

Enkele Wielen			V						FV					FSV							
8FG/D45N	Neighoek, voorw.	deg	6	6	6	6	6	6	6	6	6	6	6	—	6	6	6	6	6	6	6
	Neighoek, achterw.	deg	12	12	12	12	6	6	12	12	12	12	12	—	6	6	6	6	6	6	6
	Hefvermogen op 500 mm LC	kg	4990	4990	4990	4990	4990	4000	4990	4990	4990	4990	4990	—	4990	4900	4500	4500	4000	3000	2300
	Hefvermogen op 600 mm LC	kg	4500	4500	4500	4500	4500	4000 (4100)	4500	4500	4500	4500	4500	—	4500	4500	4200 (4300)	4200 (4250)	4000 (4050)	3000 (3050)	2300 (2350)
8FG/D50N	Neighoek, voorw.	deg	6	6	6	6	6	6	—	—	—	—	—	6	6	6	—	6	6	6	6
	Neighoek, achterw.	deg	12	12	12	12	6	6	—	—	—	—	—	6	6	6	—	6	6	6	6
	Hefvermogen op 600 mm LC	kg	5000	5000	5000	5000	5000	4000 (4150)	—	—	—	—	—	5000	4900 (4950)	4800 (4850)	—	4300 (4350)	4100 (4150)	3100 (3150)	2400 (2450)

Dubbele Wielen			V						FV					FSV							
8FG/D45N	Neighoek, voorw.	deg	6	6	6	6	6	6	6	6	6	6	6	—	6	6	6	6	6	6	6
	Neighoek, achterw.	deg	12	12	12	12	12	12	12	12	12	12	12	—	6	6	6	6	6	6	6
	Hefvermogen op 500 mm LC	kg	4990	4990	4990	4990	4990	4600	4990	4990	4990	4990	4990	—	4990	4900	4700	4700	4600	4400	4200
	Hefvermogen op 600 mm LC	kg	4500	4500	4500	4500	4500	4400	4500	4500	4500	4500	4500	—	4500	4500	4400	4400	4300	4100	3900
8FG/D50N	Tilt range, forward	deg	6	6	6	6	6	6	—	—	—	—	—	6	6	6	—	6	6	6	6
	Tilt range, backward	deg	12	12	12	12	12	12	—	—	—	—	—	6	6	6	—	6	6	6	6
	Hefvermogen op 600 mm LC	kg	5000	5000	5000	5000	5000	4800	—	—	—	—	—	5000	4900	4800	—	4600	4500	4300	4100

() = Hefvermogen met PSC wielen.

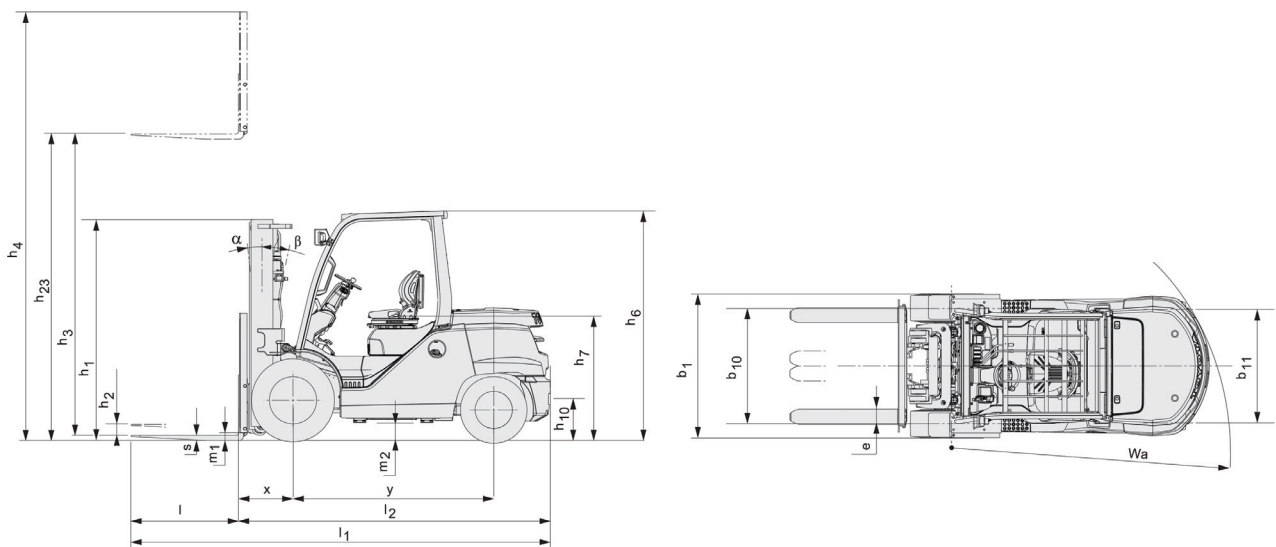

Vorkheftrucks met verbrandingsmotor 6.0 - 8.0 t

Specificaties					40-8FD60N	40-8FD70N	40-8FD80N
Kenmerken	1.1	Fabrikant			TOYOTA	TOYOTA	TOYOTA
	1.2	Type			40-8FD60N	40-8FD70N	40-8FD80N
	1.3	Aandrijving			Diesel	Diesel	Diesel
	1.4	Besturing			Zittend	Zittend	Zittend
	1.5	Hefvermogen	Q	kg	6000	7000	8000
	1.6	Bij lastzwaartepunt	c	mm	600	600	600
	1.8	Lastafstand	x	mm	580	585	590
	1.9	Wielbasis	y	mm	2250	2250	2250
	Gewicht	2.1	Eigen gewicht		kg	8360	9090
2.2		Asbelasting met last voor/achter		kg	12850/1510	14330/1760	15860/2080
2.3		Asbelasting zonder last voor/achter		kg	3705/4655	3640/5450	3630/6310
Wielen en banden	3.1	Banden - Lucht (P), Volrubber (SE), Cushion (R)			P	P	P
	3.2	Bandenmaat voor			8.25-15-14PR	8.25-15-14PR	8.25-15-14PR
	3.3	Bandenmaat achter			8.25-15-14PR	8.25-15-14PR	8.25-15-14PR
	3.5	Wielen, aantal voor/achter (x = aangedreven)			4/2	4/2	4/2
	3.6	Spoorbreedte voor	b ₁₀	mm	1440	1440	1440
	3.7	Spoorbreedte achter	b ₁₁	mm	1460	1460	1460
	Afmetingen	4.1	Neiging mast/voorover/achterover	α/β	deg	6/12	6/12
4.2		Bouwhoogte, mast ingeschoven	h ₁	mm	2460	2460	2610
4.3		Vrije heffing	h ₂	mm	125	125	130
4.4		Hefbeweging	h ₃	mm	2940	2935	2930
		Hefhoogte	h ₂₃	mm	3000	3000	3000
4.5		Hoogte, mast in hoogste stand	h ₄	mm	4435	4435	4440
4.7		Hoogte beschermdak (cabine)	h ₆	mm	2385	2385	2385
4.8		Zithoogte	h ₇	mm	1128	1128	1128
4.12		Hoogte trekpen	h ₁₀	mm	485	485	485
4.19		Totale lengte	l ₁	mm	4690	4745	4790
4.20		Lengte incl. vorkrug	l ₂	mm	3490	3545	3590
4.21		Totale breedte	b ₁	mm	1965	1965	1965
4.22		Vorkafmetingen	s/e/l	mm	60/150/1200	65/150/1200	70/150/1200
4.23		Vorkenbord DIN 15173, klasse/type A, B			IVA	IVA	IVA
4.24		Breedte vorkenbord	b ₃	mm	1700	1700	1700
4.31		Bodemvrijheid belast, onderkant mast	m ₁	mm	125	125	125
4.32		Bodemvrijheid midden wielbasis	m ₂	mm	250	250	250
4.33		Gangpadbreedte bij pallets 1000 x 1200 dwars	A _{st}	mm	5010	5065	5110
4.34	Gangpadbreedte bij pallets 800 x 1200 langs	A _{st}	Mm	5210	5265	5310	
4.35	Draaistraal	W _a	mm	3230	3280	3320	
4.36	Binnenstraal	b ₁₃	mm	930	980	1020	
Prestaties	5.1	Rijsnelheid met/zonder last		km/h	19/21	19/21	19/21
	5.2	Hefsnelheid met/zonder last		m/s	0,39/0,42	0,38/0,42	0,36/0,42
	5.3	Daalsnelheid met/zonder last		m/s	0,53/0,48	0,53/0,48	0,53/0,48
	5.6	Maximale trekkracht met/zonder last		N	46000/20500	45000/19500	45000/19300
	5.7	Klimvermogen met/zonder last		%	24	21	19
	5.8	Maximaal klimvermogen met/zonder last		%	34/24	30/21	27/18
5.10	Bedrijfsrem			Hydraulisch	Hydraulisch	Hydraulisch	
Motor	7.1	Fabrikant motor / type			TOYOTA 1KD	TOYOTA 1KD	TOYOTA 1KD
	7.2	Motorvermogen volgens 1585		kW	55	55	55
	7.3	Bij toerental		1/min	2200	2200	2200
	7.4	Aantal cilinders / cilinderinhoud		cm ³	4/2982	4/2983	4/2984
	7.5	Brandstofverbruik volgens VDI-cyclus 60		l/h	6,7	7,4	8,2
Andere	8.2	Werkdruk voor aanbouwapparatuur		bar	210	210	210
	8.3	Olie voor aanbouwapparatuur		l/min	128	128	128
	8.4	Geluidsniveau op oorhoogte chauffeur, soort EN 12 053		dB(A)	79	79	79

De prestaties en afmetingen van de truck zijn gebaseerd op nominale waarden. Hierop zijn enige afwijkingen mogelijk. De producten van Toyota en de technische gegevens van de producten kunnen zonder voorafgaand bericht worden gewijzigd.

Mastspecificaties and restcapaciteit

Model			V								FSV					
40-8FD60N	Hefhoogte	h_{23}	3000	3300	3500	3700	4000	4500	5000	5500	6000	4000	4300	4700	5000	6000
	Hefbeweging	h_3	2940	3240	3440	3640	3940	4440	4940	5440	5940	3940	4240	4640	4940	5940
	Masthoogte, mast ingeschoven	h_1	2460	2610	2710	2810	3060	3310	3560	3810	4060	2360	2460	2550	2810	3110
	Masthoogte, mast in hoogste stand ¹⁾	h_4	3980	4280	4480	4680	4980	5480	5980	6480	6980	5060	5360	5750	6160	7110
	Masthoogte, mast in hoogste stand ²⁾	h_4	4435	4735	4935	5135	5435	5935	6435	6935	7435	5435	5735	6135	6435	7435
	Vrije heffing, zonder lastrek	h_2	125	125	125	125	125	125	125	125	125	1365	1465	1565	1715	2065
	Vrije heffing, met lastrek	h_2	125	125	125	125	125	125	125	125	125	990	1090	1180	1440	1740

Model			V								FSV					
40-8FD70N	Hefhoogte	h_{23}	3000	3300	3500	3700	4000	4500	5000	5500	6000	4000	4300	4700	5000	6000
	Hefbeweging	h_3	2935	3235	3435	3635	3935	4435	4935	5435	5935	3935	4235	4635	4935	5935
	Masthoogte, mast ingeschoven	h_1	2460	2610	2710	2810	3060	3310	3560	3810	4060	2360	2460	2550	2810	3110
	Masthoogte, mast in hoogste stand ¹⁾	h_4	3980	4280	4480	4680	4980	5480	5980	6480	6980	5060	5360	5750	6160	7110
	Masthoogte, mast in hoogste stand ²⁾	h_4	4435	4735	4935	5135	5435	5935	6435	6935	7435	5435	5735	6135	6435	7435
	Vrije heffing, zonder lastrek	h_2	125	125	125	125	125	125	125	125	125	1365	1465	1565	1715	2065
	Vrije heffing, met lastrek	h_2	125	125	125	125	125	125	125	125	125	990	1090	1180	1440	1740

Model			V								FSV					
40-8FD80N	Hefhoogte	h_{23}	3000	3300	3500	3700	4000	4500	5000	5500	6000	—	—	—	—	—
	Hefbeweging	h_3	2930	3230	3430	3630	3930	4430	4930	5430	5930	—	—	—	—	—
	Masthoogte, mast ingeschoven	h_1	2610	2710	2810	3060	3310	3560	3810	4060	4310	—	—	—	—	—
	Masthoogte, mast in hoogste stand ¹⁾	h_4	4085	4385	4585	4785	5085	5585	6085	6585	7085	—	—	—	—	—
	Masthoogte, mast in hoogste stand ²⁾	h_4	4440	4740	4940	5140	5440	5940	6440	6940	7440	—	—	—	—	—
	Vrije heffing, zonder lastrek	h_2	130	130	130	130	130	130	130	130	130	—	—	—	—	—
	Vrije heffing, met lastrek	h_2	130	130	130	130	130	130	130	130	130	—	—	—	—	—

1) Zonder lastrek.

2) Met lastrek; Hoogte standaard lastrek is 1370 mm.

Dubbele Wielen			V								FSV					
40-8FD60N	Neighoek, voorw.	deg	6	6	6	6	6	6	6	6	6	6	6	6	6	6
	Neighoek, achterw.	deg	12	12	12	12	12	12	12	12	12	6	6	6	6	6
	Hefvermogen op 600 mm LC	kg	6000	6000	6000	6000	6000	6000	6000	6000	5700	5700	5700	5500	5500	5200
40-8FD70N	Neighoek, voorw.	deg	6	6	6	6	6	6	6	6	6	6	6	6	6	6
	Neighoek, achterw.	deg	12	12	12	12	12	12	12	12	12	6	6	6	6	6
	Hefvermogen op 600 mm LC	kg	7000	7000	7000	7000	7000	7000	4000	6700	6500	6700	6700	6700	6700	5700
40-8FD80N	Neighoek, voorw.	deg	6	6	6	6	6	6	6	6	6	—	—	—	—	—
	Neighoek, achterw.	deg	12	12	12	12	12	12	12	12	12	—	—	—	—	—
	Hefvermogen op 600 mm LC	kg	8000	8000	8000	8000	8000	8000	8000	7700	7500	—	—	—	—	—

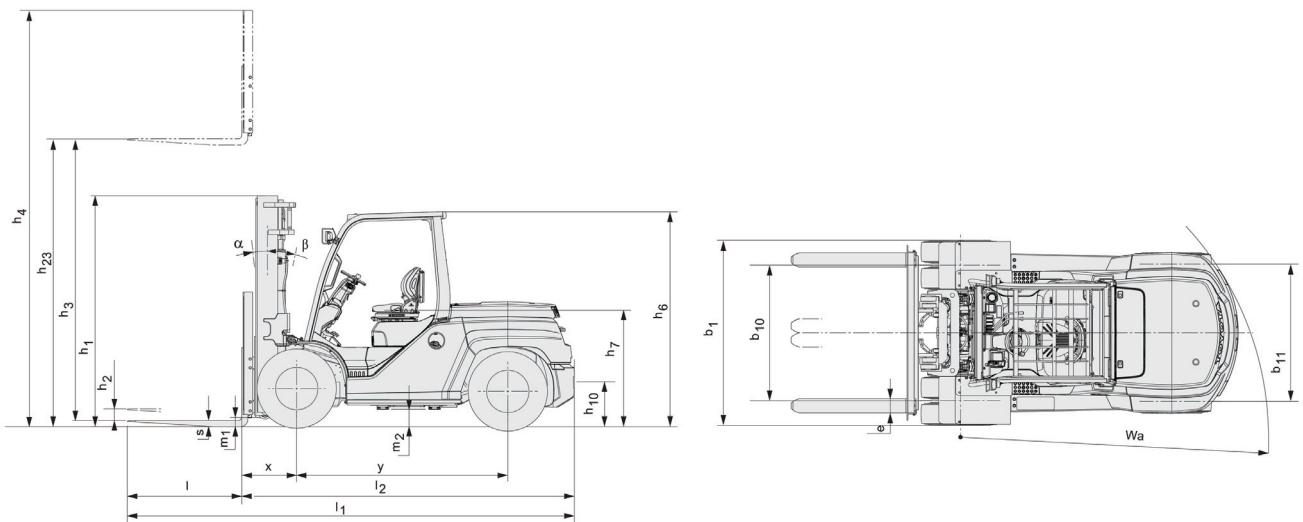

Standaard uitrusting:

- Hydrodynamische transmissie
- Toyota SAS (Systeem van Actieve Stabiliteit*)
- Toyota OPS (Sensor Aanwezigheid Bestuurder)
- Doorkijkmast (Hefhoogte: 3000 mm)
- Lastbeschermrek [Hoogte 1220 mm (8FG/D35.40.45N); 1370 mm (8FG/D50.60.70.80N)]
- Lange vorken [Lengte: 1000 mm (8FG/D35.40.45N); 1200 mm (8FG/D50.60.70.80N)]
- Breder vorkenbord [Breedte: 1170 mm (8FG/D35.40.45.50N); 1700 (8FG/D60.70.80N)]
- 3e Stuurventiel (A400)
- Dubbel remsysteem
- Volrubberbanden
- Hydraulische stuurbekrachtiging
- Cycloon luchtfilter
- Werklichten
- Stads-, stop- en achteruitrijlichten achteraan
- Metercombinatie met zelfdiagnosesysteem
- Verstelbare stuurkolom

* = Met dubbele aandrijfwielen wordt de truck af fabriek geleverd zonder Actieve Achterasstabilisator van het SAS-systeem.

The logo for Grobeco heftrucks features the word "Grobeco" in a bold, black, sans-serif font. To the left of "Grobeco" is a red, curved graphic element resembling a stylized 'G' or a swoosh. Below "Grobeco", the word "heftrucks" is written in a smaller, grey, lowercase sans-serif font.