

# Elektrische Vorkheftrucks 1.6 - 2.0 t

**TRIGO<sup>48</sup>**

4 wiel



# Elektrische Vorkheftrucks 1.6 - 2.0 t

Specificaties				8FBMK16T	8FBM16T	8FBM18T	8FBMK20T	8FBM20T	
Kenmerken	1.1	Fabrikant		TOYOTA	TOYOTA	TOYOTA	TOYOTA	TOYOTA	
	1.2	Type		8FBMK16T	8FBM16T	8FBM18T	8FBMK20T	8FBM20T	
	1.3	Aandrijving		Elektro	Elektro	Elektro	Elektro	Elektro	
	1.4	Besturing		Zittend	Zittend	Zittend	Zittend	Zittend	
	1.5	Hefvermogen	Q	kg	1600	1600	1800	2000	2000
	1.6	Bij lastzwaartepunt	c	mm	500	500	500	500	500
	1.8	Lastafstand	x	mm	317	317	317	317	317
	1.9	Wielbasis	Y	mm	1453	1561	1561	1453	1561
	Gewicht	2.1	Eigen gewicht		2952	2973	3071	3274	3261
2.2		Asbelasting met last voor/achter		4056/496	4077/496	4368/503	4661/613	4708/553	
2.3		Asbelasting zonder last voor/achter		1500/1452	1586/1387	1573/1498	1480/1794	1609/1652	
Wielen en banden	3.1	Banden - Lucht (P), Volrubber (SE), Cushion (R)		SE	SE	SE	SE	SE	
	3.2	Bandenmaat voor		18x7-8	18x7-8	18x7-8	200/50-10	200/50-10	
	3.3	Bandenmaat achter		16x6-8	16x6-8	16x6-8	16x6-8	16x6-8	
	3.5	Wielen, aantal voor/achter (x = aangedreven)		2x/2	2x/2	2x/2	2x/2	2x/2	
	3.6	Spoorbreedte voor	b <sub>10</sub>	mm	905	905	905	925	925
	3.7	Spoorbreedte achter	b <sub>11</sub>	mm	880	880	880	880	880
	Afmetingen	4.1	Neiging mast/voorover/achterover	$\alpha/\beta$	deg	5/7	5/7	5/7	5/7
4.2		Bouwhoogte, mast ingeschoven	h <sub>1</sub>	mm	2120	2120	2120	2120	2120
4.3		Vrije heffing	h <sub>2</sub>	mm	115	115	115	115	115
4.4		Hefbeweging	h <sub>3</sub>	mm	3265	3265	3265	3265	3265
		Hefhoogte	h <sub>23</sub>	mm	3300	3300	3300	3300	3300
4.5		Hoogte, mast in hoogste stand	h <sub>4</sub>	mm	3870	3870	3870	3870	3870
4.7		Hoogte beschermdak (cabine)	h <sub>6</sub>	mm	2055	2055	2055	2055	2055
4.8		Zithoogte	h <sub>7</sub>	mm	954	954	954	954	962
4.12		Hoogte trekpen	h <sub>10</sub>	mm	427	427	427	427	427
4.19		Totale lengte	l <sub>1</sub>	mm	3014	3122	3122	3014	3122
4.20		Lengte incl. vorkrug	l <sub>2</sub>	mm	2014	2122	2122	2014	2122
4.21		Totale breedte	b <sub>1</sub>	mm	1060	1060	1060	1152	1152
4.22		Vorkafmetingen	s/e/l	mm	35/100/1000	35/100/1000	35/100/1000	35/120/1000	35/120/1000
4.23		Vorkenbord DIN 15173, klasse/type A, B			I/A	I/A	I/A	I/A	I/A
4.24		Breedte vorkenbord	b <sub>3</sub>	mm	920	920	920	920	920
4.31		Bodemvrijheid belast, onderkant mast	m <sub>1</sub>	mm	80	80	80	90	90
4.32	Bodemvrijheid midden wielbasis	m <sub>2</sub>	mm	101	101	101	107	107	
4.33	Gangpadbreedte bij pallets 1000 x 1200 dwars	A <sub>st</sub>	mm	3327	3438	3438	3327	3438	
4.34	Gangpadbreedte bij pallets 800 x 1200 langs	A <sub>st</sub>	mm	3460	3568	3568	3460	3568	
4.35	Draaistraal	W <sub>a</sub>	mm	1707	1811	1811	1707	1811	
4.36	Binnenstraal	b <sub>13</sub>	mm	68	49	49	68	49	
Prestaties	5.1	Rijsnelheid met/zonder last		km/h	20/20	20/20	20/20	20/20	20/20
	5.2	Hefsnelheid met/zonder last		m/s	0,43/0,61	0,43/0,61	0,42/0,61	0,38/0,54	0,38/0,54
	5.3	Daalsnelheid met/zonder last		m/s	0,53/0,55	0,53/0,55	0,53/0,55	0,52/0,50	0,52/0,50
	5.5	Trekkkracht met/zonder last		N	5083/5171	4998/5143	4998/5143	4851/5055	4851/5055
	5.6	Maximale trekkkracht met/zonder last		N	9534/9437	9448/9409	9448/9409	9157/9197	9157/9197
	5.7	Klimvermogen met/zonder last		%	17,3/22,4	15,3/24,2	15,3/24,2	13,4/24,6	13,4/24,6
	5.8	Maximaal klimvermogen met/zonder last		%	23,6/22,4	21,0/24,2	21,0/24,2	18,3/24,6	18,3/24,6
	5.9	Versnellingsstijd, met/zonder last (0—10 m)		s	4,6/4,2	4,6/4,2	4,7/4,3	4,7/4,3	4,7/4,3
	5.10	Bedrijfsrem			Hydraulisch	Hydraulisch	Hydraulisch	Hydraulisch	Hydraulisch
	Electric motor	6.1	Rijmotorvermogen S2 60 min		kW	6x2	6x2	6x2	6x2
6.2		Pompmotorvermogen bij S3 15%		kW	11	11	11	11	11
6.3		Batterij volgens DIN 43531/35/36 A, B, C, nee			43 531A	43 531A	43 531A	43 531A	43 531A
6.4		Batterijspanning/batterijcapaciteit K <sub>5</sub>		V/Ah	48/550-625	48/660-750	48/660-750	48/550-625	48/660-750
6.5		Batterijgewicht		kg	856	1013	1013	856	1013
6.6		Energieverbruik volgens VDI-cyclus		kWh/h	5,1	5,4	5,6	6,3	6,4
Andere	8.1	Aandrijving			MOSFET	MOSFET	MOSFET	MOSFET	MOSFET
	8.2	Werkdruk voor aanbouwapparatuur		bar	183	183	183	183	183
	8.3	Olie voor aanbouwapparatuur		l/min	41,3	41,3	41,3	41,3	41,3
	8.4	Geluidsniveau op oorhoogte chauffeur, soort EN 12 053		dB(A)	72,3	72,3	72,3	72,3	72,3

De prestaties en afmetingen van de truck zijn gebaseerd op nominale waarden. Hierop zijn enige afwijkingen mogelijk. De producten van Toyota en de technische gegevens van de producten kunnen zonder voorafgaand bericht worden gewijzigd.

# Mastspecificaties and restcapaciteit

Model			V								FV				FW				FSV						FSW							
8FBMK16T/18T/20T	Hefhoogte	$h_{23}$	3000	3300	3500	3700	4000	4500	5000	3000	3300	3500	3700	3000	3300	3500	3700	4300	4500	4700	5000	5500	6000	4300	4500	4700	5000	5500	6000	6500	7000	7500
	Hefbeweging	$h_3$	2965	3265	3465	3665	3965	4465	4965	2965	3265	3465	3665	2965	3265	3465	3665	4265	4465	4665	4965	5465	5965	4265	4465	4665	4965	5465	5965	6465	6965	7465
	Masthoogte, mast ingeschoven	$h_1$	1970	2120	2220	2380	2570	2820	3070	1970	2120	2220	2380	2000	2150	2250	2350	1970	2040	2120	2220	2380	2570	1980	2050	2150	2250	2450	2600	2800	3000	3200
	Masthoogte, mast in hoogste stand <sup>1)</sup>	$h_4$	3570	3870	4070	4270	4570	5070	5570	3580	3880	4080	4280	3555	3855	4055	4255	4845	5045	5245	5545	6045	6545	4845	5045	5245	5545	6045	6545	7045	7545	8045
	Masthoogte, mast in hoogste stand <sup>2)</sup>	$h_4$	4260	4560	4760	4960	5260	5760	6260	4260	4560	4760	4960	4260	4560	4760	4960	5560	5760	5960	6260	6760	7260	5560	5760	5960	6260	6760	7260	7760	8260	8760
	Vrije heffing, zonder lastrek	$h_2$	115	115	115	115	115	115	115	1425	1575	1675	1835	1485	1635	1735	1835	1450	1520	1600	1700	1860	2050	1475	1545	1645	1745	1945	2095	2295	2495	2695
Vrije heffing, met lastrek	$h_2$	115	115	115	115	115	115	115	745	895	995	1155	780	930	1030	1130	745	815	895	995	1155	1345	760	830	930	1030	1230	1380	1580	1780	1980	

1) Zonder lastrek.

2) Met lastrek; Hoogte standaard lastrek is 1220 mm.

Luchtbanden			V								FV				FW				FSV						FSW						
8FBMK16T	Neigehoek, voorw.	deg	5	5	5	5	5	5	5	5	5	5	5	5	5	5	5	5	5	5	5	5	5	5	5	5	5	5	5	5	
	Neigehoek, achterw.	deg	7(5)	7(5)	7(5)	7(5)	7(5)	7(5)	7(5)	7(5)	7(5)	7(5)	7(5)	7(5)	7(5)	7(5)	7(5)	7(5)	7(5)	7(5)	7(5)	7(5)	7(5)	7(5)	7(5)	7(5)	7(5)	7(5)	7(5)	7(5)	
	Hefvermogen op 500 mm LC	kg	1600	1600	1600	1600	1600	1600	1450	1600	1600	1600	1600	1600	1600	1600	1600	1550	1550	1500	1450	1400	1250	1550	1550	1500	1450	1400	1250	1100	950
8FBM16T	Neigehoek, voorw.	deg	5	5	5	5	5	5	5	5	5	5	5	5	5	5	5	5	5	5	5	5	5	5	5	5	5	5	5	5	
	Neigehoek, achterw.	deg	7(5)	7(5)	7(5)	7(5)	7(5)	7(5)	7(5)	7(5)	7(5)	7(5)	7(5)	7(5)	7(5)	7(5)	7(5)	7(5)	7(5)	7(5)	7(5)	7(5)	7(5)	7(5)	7(5)	7(5)	7(5)	7(5)	7(5)	7(5)	
	Hefvermogen op 500 mm LC	kg	1600	1600	1600	1600	1600	1600	1600	1600	1600	1600	1600	1600	1600	1600	1600	1600	1600	1600	1550	1450	1200	1600	1600	1600	1550	1450	1200	1000	800
8FBM18T	Neigehoek, voorw.	deg	5	5	5	5	5	5	5	5	5	5	5	5	5	5	5	5	5	5	5	5	5	5	5	5	5	5	5	5	
	Neigehoek, achterw.	deg	7(5)	7(5)	7(5)	7(5)	7(5)	7(5)	7(5)	7(5)	7(5)	7(5)	7(5)	7(5)	7(5)	7(5)	7(5)	7(5)	7(5)	7(5)	7(5)	7(5)	7(5)	7(5)	7(5)	7(5)	7(5)	7(5)	7(5)	7(5)	
	Hefvermogen op 500 mm LC	kg	1800	1800	1800	1800	1800	1750	1700	1800	1800	1800	1800	1800	1800	1800	1800	1800	1700	1700	1700	1680	1450	1700	1700	1700	1680	1480	1250	1100	850
8FBMK20T	Neigehoek, voorw.	deg	5	5	5	5	5	5	5	5	5	5	5	5	5	5	5	5	5	5	5	5	5	5	5	5	5	5	5	5	
	Neigehoek, achterw.	deg	7(5)	7(5)	7(5)	7(5)	7(5)	7(5)	7(5)	7(5)	7(5)	7(5)	7(5)	7(5)	7(5)	7(5)	7(5)	7(5)	7(5)	7(5)	7(5)	7(5)	7(5)	7(5)	7(5)	7(5)	7(5)	7(5)	7(5)	7(5)	
	Hefvermogen op 500 mm LC	kg	2000	2000	2000	2000	2000	1950	2000	2000	2000	2000	2000	2000	2000	2000	2000	2000	1950	1950	1950	1800	1650	1950	1950	1950	1900	1850	1600	1200	900
8FBM20T	Neigehoek, voorw.	deg	5	5	5	5	5	5	5	5	5	5	5	5	5	5	5	5	5	5	5	5	5	5	5	5	5	5	5	5	
	Neigehoek, achterw.	deg	7(5)	7(5)	7(5)	7(5)	7(5)	7(5)	7(5)	7(5)	7(5)	7(5)	7(5)	7(5)	7(5)	7(5)	7(5)	7(5)	7(5)	7(5)	7(5)	7(5)	7(5)	7(5)	7(5)	7(5)	7(5)	7(5)	7(5)	7(5)	
	Hefvermogen op 500 mm LC	kg	2000	2000	2000	2000	2000	1900	2000	2000	2000	2000	2000	2000	2000	2000	2000	2000	1950	1950	1900	1800	1650	1950	1950	1900	1850	1600	1350	1050	950

Data tussen ( ) zijn wanneer cabine optie (type, minimaal voorruit) is geselecteerd.

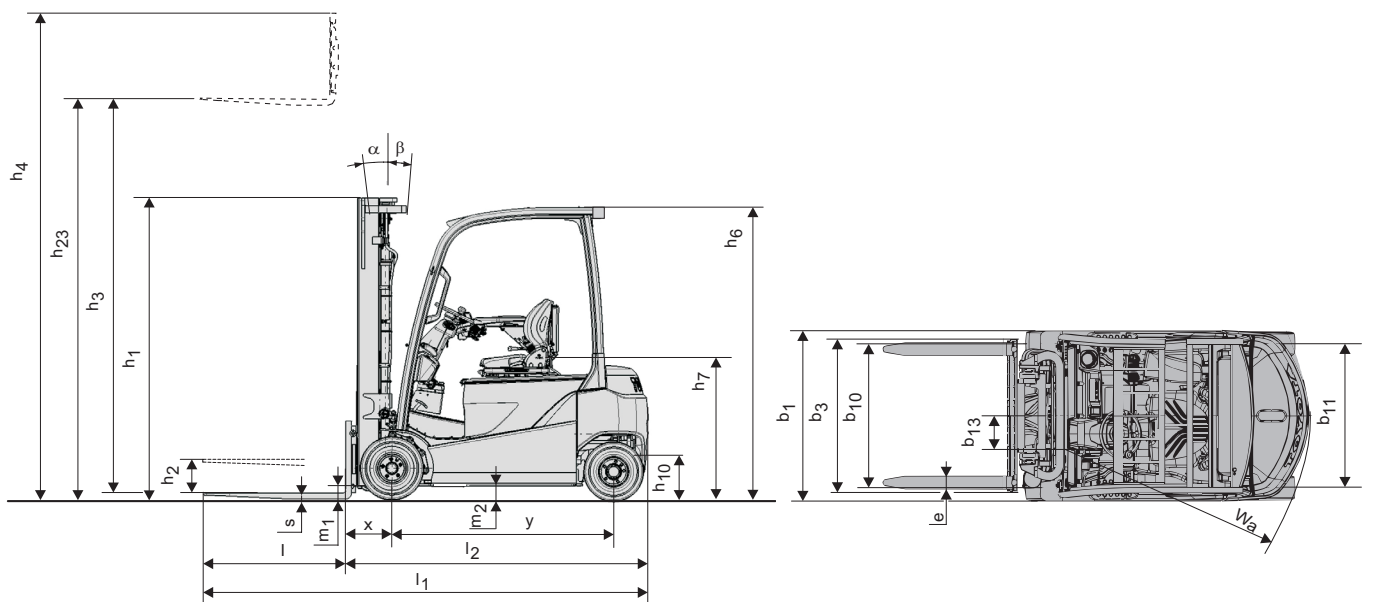

## Standaard uitrusting

- Toyota SAS (Systeem van Actieve Stabiliteit)
- Toyota AC<sup>2</sup> Systeem
- Toyota ORS stoel (Operator Restraint System)
- Aan stoel gemonteerde armsteun met minilevers
- Doorkijkmast (Hefhoogte:3300)
- Lange vorken (Lengte:1000mm)
- Breder vorkenbord (Breedte: 920mm)
- 3<sup>e</sup> Stuurventiel
- Oliebadremmen
- Volrubberbanden
- Volledig hydraulische stuurbekrachtiging
- Digitaal multifunctioneel display met wielstandindicatie
- Verstelbare stuurkolom met geheugen



TP-Technical Publications, Sweden — 745556-360, version 4, 1510